

ARAMIS



Optical 3D Deformation Analysis

3D Surface - Displacements - Strains
in Material and Component Testing



Trilion Quality Systems

www.trilion.com



Optical 3D Deformation Analysis

ARAMIS helps to better understand material and component behavior and is ideally suited to monitor experiments with high temporal and local resolution. ARAMIS is a non-contact and material independent measuring system providing, for static or dynamically loaded test objects, accurate:

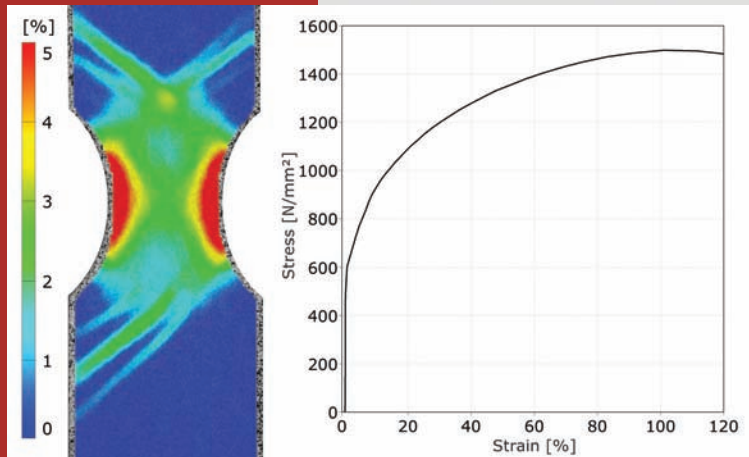

- 3D surface coordinates
- 3D displacements and velocities
- Surface strain values
- Strain rates

Unlike other techniques, ARAMIS is a robust solution for full-field analysis of small specimens (mm) up to large components (multiple 10 m). Measurements are carried out independently from geometry and temperature without time-consuming and expensive specimen preparation.

ARAMIS is the solution for ...

- Determination of material properties
- Component analysis
- Verification of Finite Element Analysis
- Real-Time controlling of testing devices

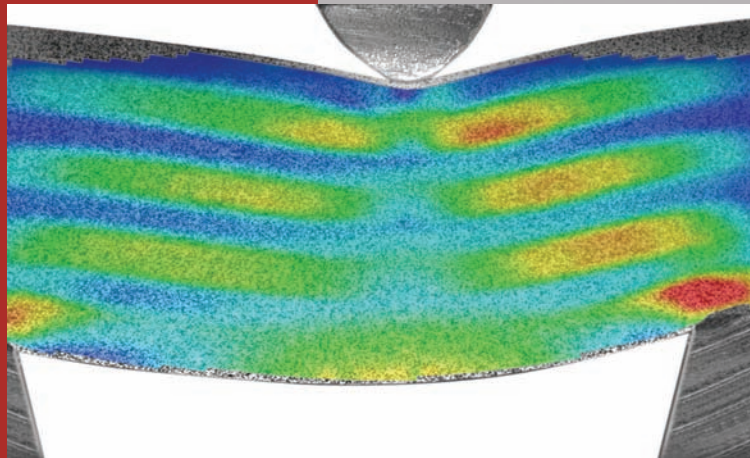

ARAMIS Features

- Non-contact
- Material independent
- Geometry independent
- 2D and 3D measurement
- Mobile and flexible
- Full-field
- High accuracy
- High temperature
- High speed
- Easy specimen preparation
- Integration in testing environments
- Smallest to largest object sizes
- Smallest to largest deformations

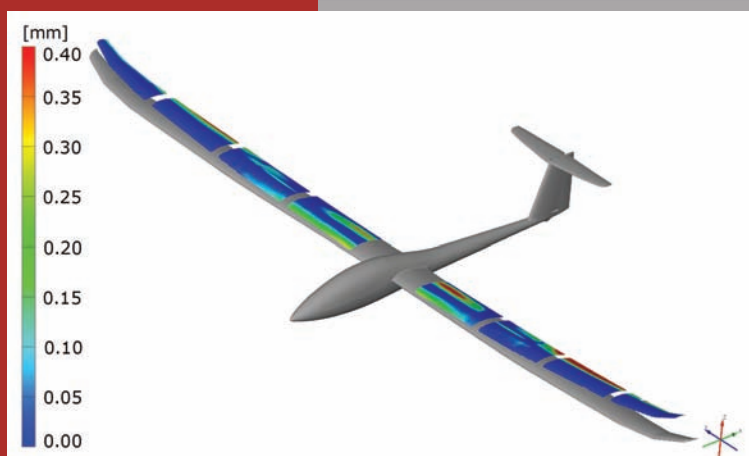

Sub-pixel accurate image processing for 3D surface, displacement and strain measurement

ARAMIS evaluates high-resolution images recorded from any test object during loading. With the help of adjustment computations, a precise mathematical calibration model of the sensor setup is calculated including camera positions and lens distortion parameters.

The image processing is based on the principle of digital image correlation. Grey value distributions are calculated for a large amount of small subsets in each camera image and provide sub-pixel accurate positions about corresponding points between all images.

The mathematical model of the sensor setup, the digital image correlation method and a triangulation calculation are combined to derive high accurate 3D coordinates. Subtracting the surface information in all loading stages in 3D space provides precise X,Y and Z displacement values.

Strains are calculated considering the component's geometry and plasticity theory. As the image acquisition is time-based, 3D velocities and strain rates are automatically achieved.

ARAMIS provides the measurement results as

- Full-field 3D coordinates, displacements and strains
- Fine resolution 3D mesh
- Plain strain tensor
- Object contour based visualization

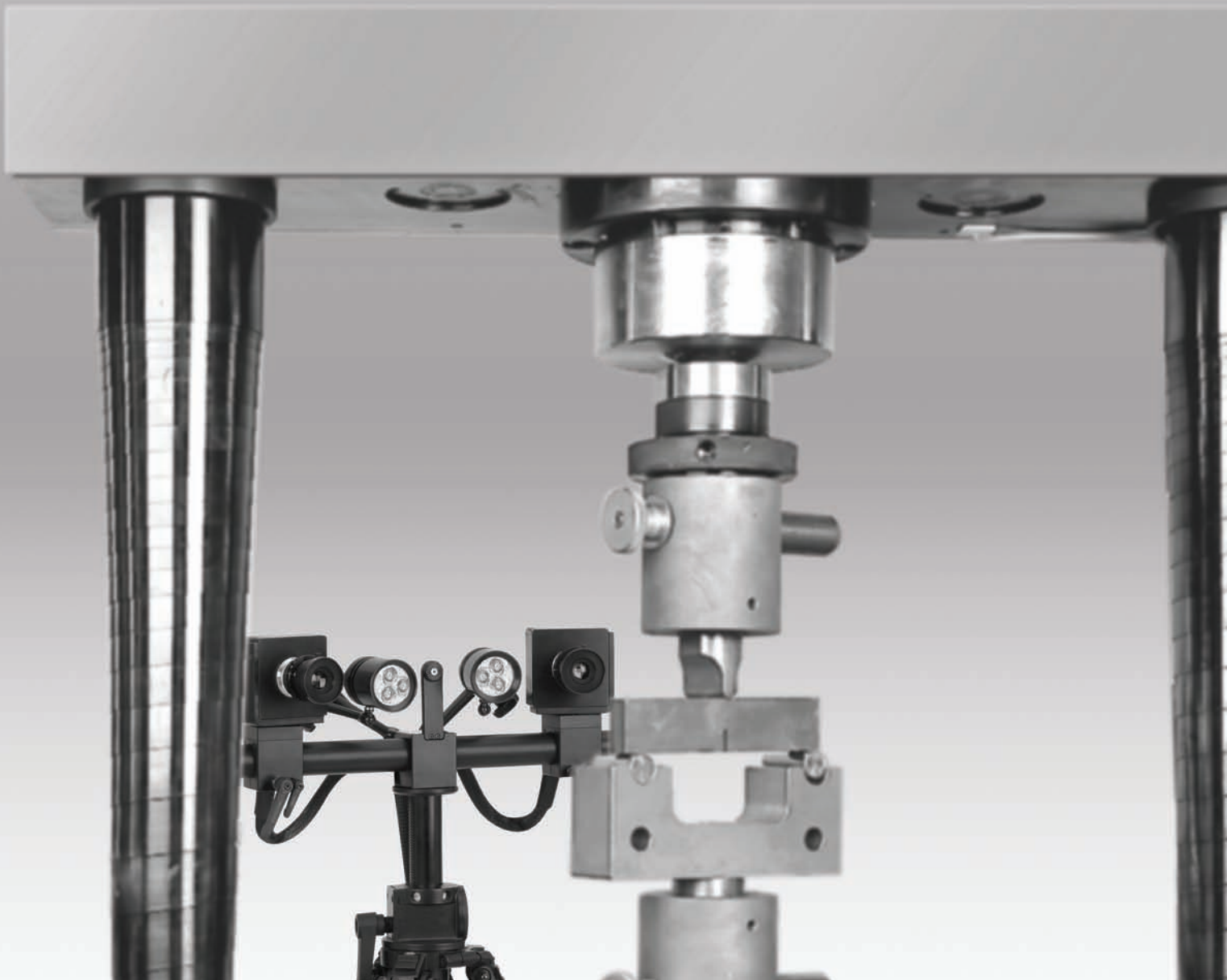

Measuring for a better understanding

Important factors in product development processes are the dimensioning of components, the exact determination of material properties and the validation of FE calculation models. ARAMIS helps to better understand material and component behavior.

Material testing

The precise full-field ARAMIS results improve the accuracy of material characteristic values.

Existing evaluation procedures are enhanced and thus more reliable, like the determination of flow curves and forming limit curves. A lot of material tests can only be evaluated because of the non-contact measurement and the high local resolution ARAMIS results.

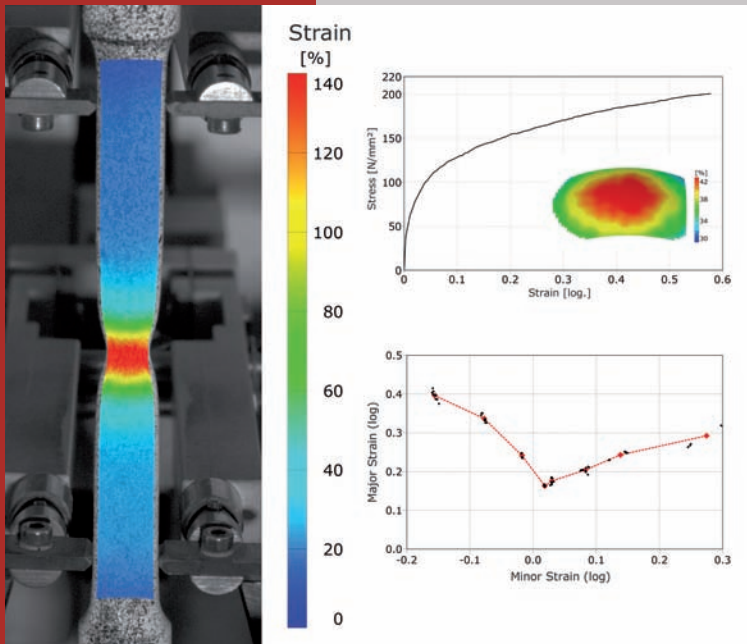

- High temperature tests
- High speed tests
- Very small specimen sizes

Today, ARAMIS is an established and proven measuring solution in hundreds of material research facilities around the world for:

- Strain-Stress evaluation
- R-Values
- Poisson ratio
- Young's modulus
- Forming limit curves
- Residual stress
- Shear modulus

Real-Time 3D measuring

ARAMIS provides real-time results for multiple measurement positions on a specimen's surface. These are directly transferred to testing devices, data acquisition units or processing softwares (e.g. LabView, DIAdem, MSeExcel, etc.) and are used for

- Controlling of testing devices
- Long-term tests with smallest storage requirements
- Vibration analysis
- 3D Video Extensometer

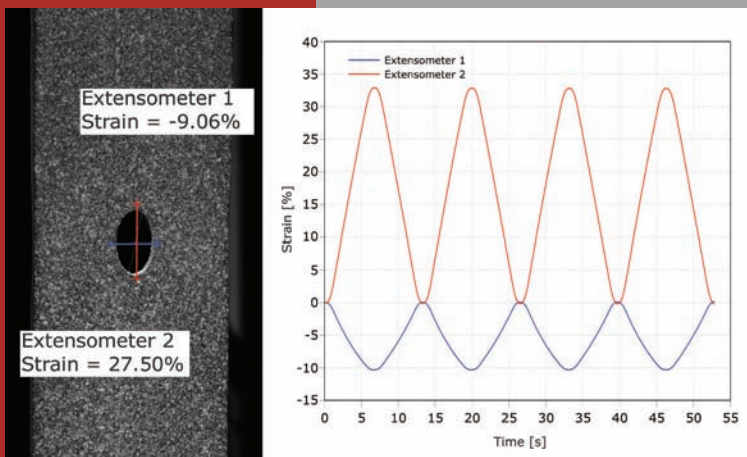

Component testing and analysis

ARAMIS is the right tool for the understanding of the component itself as it is

- independent from material, size and geometry
- and measuring under real-use conditions.

ARAMIS considers the real component geometry which would not be possible with traditional measuring devices like strain gauges, displacement sensors (LVDT), vibrometers, etc.

3D measurement results are always required as a 3D object leads to non-linear deformation behavior. ARAMIS links to the component's original 3D CAD data for transformations, direct comparisons and visualizations.

ARAMIS provides all results for static and dynamic tests even at high speeds for smallest to largest components for

- Strength assessment
- Vibration analysis
- Durability studies
- Crash tests

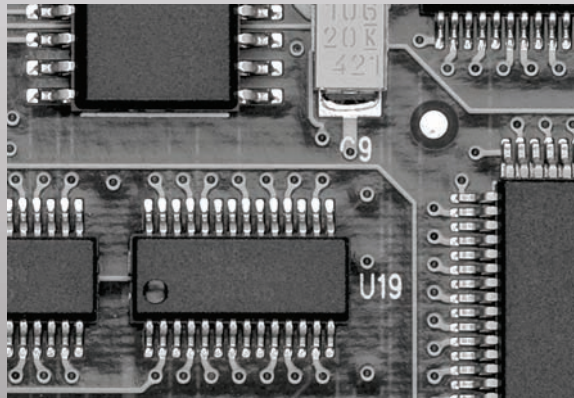

Finite Element Analysis

New products and production processes are designed and optimized with numerical simulation methods. Material parameters and component deformation behavior have a significant influence on the accuracy of simulation calculations and their reliability.

ARAMIS is used for the determination of material parameters as FE input values and the validation of numerical simulations by calculating the differences between experimental measurements and FE data.

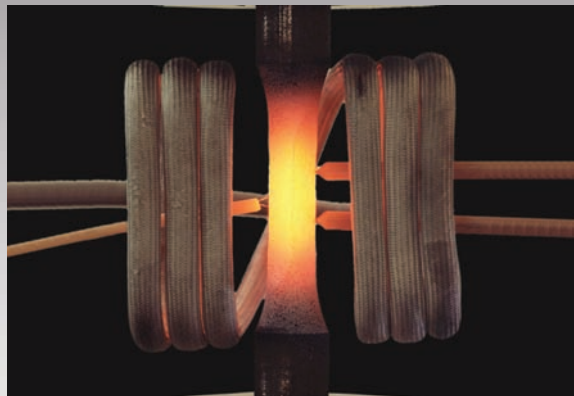

The basic workflow

Preparation

The mobile ARAMIS sensor is adjusted to the required specimen size and positioned in front of the specimen.

Measurement

ARAMIS acquires the images and analog data during loading of the component.

- User-definable image acquisition
- Flexible triggering (manual, time sequence, TTL, analog signals)
- Integrated data logger
- Real-Time measurement

Evaluation

ARAMIS automatically computes 3D coordinates for all loading stages and derives surface, displacement and strain results.

- Computation of material parameters
- CAD import and comparison
- Coordinate transformation (3-2-1, CAD, Best-Fit, ...)
- Rigid body motion compensation
- Calculation of geometrical elements (cylinders, circles, cones, spheres, planes, ...)
- Evaluation of acquired analog data
- Comparison to Finite Element Simulation including import and export

Reporting

The ARAMIS reporting engine is based on templates for complete automatic report generation. All results are available for user-definable 3D visualizations, diagrams, tables, videos, images and can be exported in standard file formats.

ARAMIS Advantages

Non-contact 3D surface, displacements and strains

ARAMIS is the unique solution delivering complete 3D surface, displacement and strain results where a large number of traditional measuring devices are required (strain gauges, LVDTs, extensometers, ...).

Local and global deformation behavior

ARAMIS results are comparable to values from hundreds or thousands of strain gauges, LVDTs and extensometers on one specimen. These full-field measurement data represent local effects and global deformations for an easy understanding of material and component behavior.

More information - faster

ARAMIS preparation and setup is easy, leading to quickly available measuring results.

From smallest to largest strains

ARAMIS is the only reasonable method to measure from smallest strains to multiple hundred percent deformation (e.g. polymer specimens with 1000% strain).

Matching the applications

ARAMIS can be set up to meet optimum measuring speeds, resolutions and areas of interest.

Sensor Controller

ARAMIS comes with an integrated sensor controller which allows adaptation to the testing environment. This controller is used for aligning the image acquisition to the test procedure, recoding analog values and communicating with testing devices.

The sensor controller is specially developed by GOM to provide an automated and secure integration in material and component testing process chains.

Process reliability

The ARAMIS sensor is based on GOM's proven stereo-camera technique, guaranteeing

- Compensating for environmental influences (e.g. room temperature, vibration)
- Monitoring the sensor calibration automatically
- Identifying and compensating rigid body motion





The Complete ARAMIS System

Cameras

- CCD and CMOS cameras
- Different image resolutions
- Adjustable image size
- User-definable acquisition speeds to meet application requirements
- Stable and certified lenses

Sensor

- Adjustable or fixed camera frame
- Robust and stable
- No tools for sensor adjustment required
- Integrated object illumination
- Integrated laser pointer for simplified positioning

Sensor Controller

- Power supply for cameras, illumination and positioning pointer
- Trigger unit
- Synchronized image acquisition
- Analogue data input and output

Computer / Notebook

- 64 bit processing power
- Industrial grade and certified components

Transport Cases

- Adjustable work plate for sitting or standing working height
- Robust and proven sensor protection case

Certification

- Certified calibration artifacts
- NIST and PTB certified software algorithms
- FCC certified computer

Software

- Complete software from one source

ARAMIS Technical Data

Configuration	5M	4M	12M	HS	High Speed
Frame Rate	15Hz up to 29Hz	60Hz up to 480Hz	24Hz up to 200Hz	500Hz up to 4000Hz	5kHz up to 1MHz
Camera Resolution	2448 x 2050 px	2352 x 1728 px	4096 x 3072 px	1280 x 1024 px	up to 1024 x 1024 px
Measuring Area	mm ² to > m ²				
Strain Measuring Range	0.01 % up to >100%				
Strain Measuring Accuracy	up to 0.01 %				
Ring Buffer	•	•	•	•	•
Image Memory	uses PC RAM	uses PC RAM	uses PC RAM	uses PC RAM	camera RAM
Camera Frame	adjustable/fixed	adjustable/fixed	adjustable/fixed	adjustable/fixed	adjustable
Tool Free Mounting	•	•	•	•	-
Integrated Cable Guide	•	•	•	•	-
Positioning Pointers	1 or 3	1 or 3	1 or 3	1 or 3	-
Illumination	integrated	integrated	integrated	external	external
High-End Rack Mount PC	•	•	•	•	•
Notebook	•	-	-	-	•
Control Device	sensor controller	sensor controller	sensor controller	sensor controller	optional
Sensor Dimensions (height x depth)	175 x 180 mm	235 x 185 mm	215 x 185 mm	230 x 185 mm	variable
Sensor Dimensions (length)	variable	variable	variable	variable	variable
Weight	5 kg	6.5 kg	6.5 kg	6 kg	5 – 40°
Operating Temperature	5 – 40°	5 – 40°	5 – 40°	5 – 40°	5 – 40°
Humidity	non-condensing	non-condensing	non-condensing	non-condensing	non-condensing
Power Supply	90-230V AC	90-230V AC	90-230V AC	90-230V AC	90-230V AC

Additional sensor configurations available on request.

Sensor Controller Technical Data

	Analog Input Channels 8 Digital Resolution 16 bit Voltage Range -10 V to +10 V Sampling Frequency up to 100 kHz	Analog Output Channels 4 Digital Resolution 12 bit Voltage Range 0 V to +10 V Sampling Frequency up to 500 Hz
	Trigger pre / direct / post Event List Based Triggering points in time, analog values, external signals	
	Power for cameras, illumination, positioning pointers Communication / Data Transfer gigabit ethernet (TCP/IP)	
	Dimensions 445 x 44 x 370 mm ³ Weight 2.8 kg Operating Temperature 5 – 40° Humidity non-condensing Power Supply 90-230V AC	

ARAMIS



Turn-key solution

GOM provides a complete solution with the ARAMIS system for measuring, evaluation and reporting.

- Optimized workflows – time saving
- User friendly – one training session
- One support contact

GOM completely develops the ARAMIS hardware and software in house. The software is designed to run the sensor and controller, to process all measurements, to automatically compute result data and to perform post-processing.

ARAMIS is an industrial grade solution providing all necessary functionalities even for complex research tasks.

ARAMIS is integrated in standard process chains through versatile import and export capabilities. Material parameters, testing device outputs and data logs are imported and used for further calculation of characteristic values.

CAD data are used for transformations and deviation calculations.

- Native: Catia v4/v5, UG, ProE
- General: IGES, STL, VDA, STEP

To close the process loop, all result data are exported in standard or free definable formats.

All workflows are available for automated use with a record and play procedure. New analysis models can easily be implemented by the operator and added to the standard evaluation as ARAMIS offers a scripting interface.

All built-in features enable ARAMIS to:

- Integrate in existing testing and measuring workflows
- Link with existing evaluation strategies
- Adapt to any measuring and evaluation task

Development, construction, support all in one

The "Gesellschaft für Optische Messtechnik" (GOM) develops, produces and distributes optical measuring equipment for the three-dimensional coordinate measurement and deformation measurement of components. The measuring systems are based on digital image processing and are used in material and component testing, product development and quality assurance.

All over the world, companies of the automotive, aviation and space industries, their suppliers and various manufacturers of consumer goods as well as research facilities use GOM systems.

GOM was founded in 1990 as spin-off of the Technical University Braunschweig, Germany. The company owns subsidiaries in Switzerland, France, Great Britain and Belgium. Worldwide, more than 30 committed and competent partners install, support and market GOM products.

Today, GOM offers a complete in-house solution covering hardware, software, technical support and training.

GOM customers (extract)

Adidas Salomon • Air Force • Airbus • Aircelle • Alcan • Arcelor • ASICS • Audi • BAM • BASF • Bayer • Belgrade University • BMW • Boeing • Bosch • Bridgestone • Canadian National Research Council • China Steel • CIDAUT • CNES • Corning • Daimler • DLR • DTU Copenhagen • DuPont • EADS • EDAG • EMPA • Eurocopter • Exxon • FAA • Faurecia • FIAT • Frauenhofer Gesellschaft • General Motors • GKSS • Goodyear • Henkel Loctite • Honda • Hydro Aluminium • Hyundai • IBM • ILVA • IMA • Imperial College • Indian Institute of Technology • Infineon • IUC • John Deere • Korea Institute of Materials Science • KTH Stockholm • Lawrence Livermore National Laboratory • LFT Erlangen • LG Electronics • Magna • Max-Planck-Institut • McMaster University • Microsoft • MTU • NASA • Northrop Grumman • Novelis • ONERA • PCCL • Pintura Estampado y Montaje • Pohang University • Politechnika Warszawska • Politecnico di Bari • PSA • Renault • RWTH Aachen • Salzgitter Mannesmann Forschung • Samara State Aerospace University • Samsung • Sandia National Laboratories • Skoda Auto • Sun Microsystems • Technical University of Liberec • TU Delft • TU Dresden • TU Graz • TU München • Union College • University of Loughborough • University of Michigan • University of Stellenbosch • University of Texas • University Bucharest • Univerza v Mariboru • Växjö Universitet • Voest-Alpine Stahl • Volkswagen • VZLU • Wichita State University • ZF Sachs

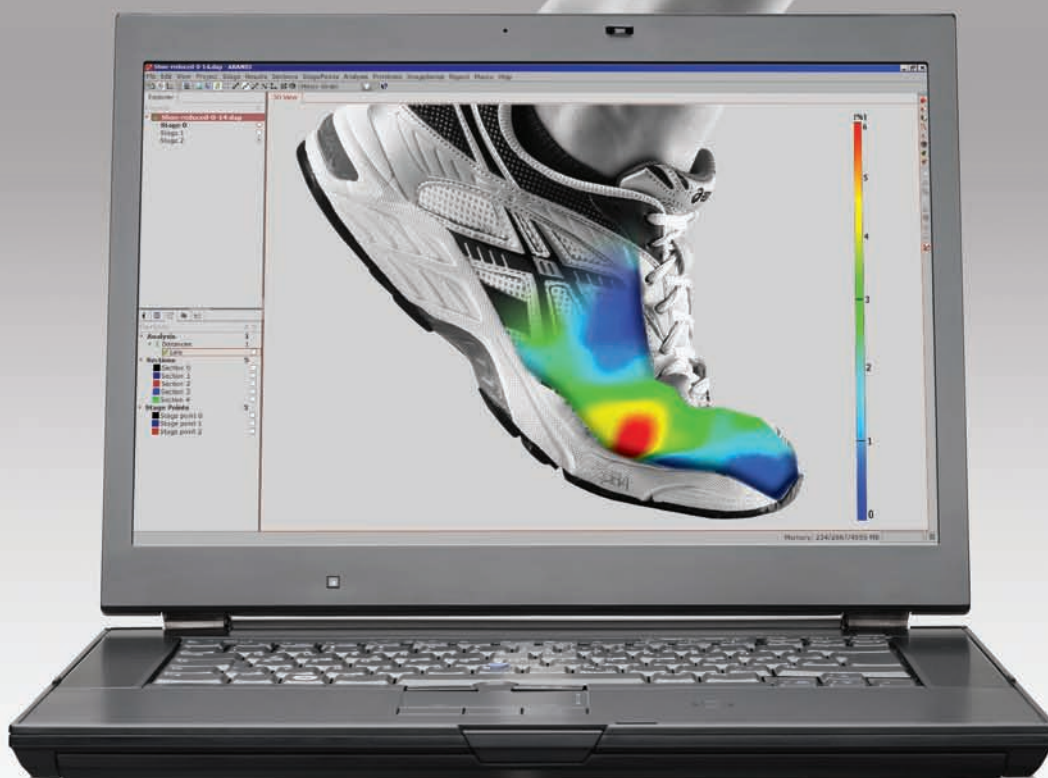

Argentina
ROBTEC ARGENTINA
Phone +54 11 4787 6800
info@robtec.com

Australia
MOSS Pty Ltd
Phone +61 3 9946 1086
scan3d@iprimus.com.au

Austria
Westcam Datentechnik GmbH
Phone +43 5223 5550 90
office@westcam.at

Belarus, Russia, Ukraine
MCP Technology
Phone +375 17 262 5612
mcp@technology@mcp.by

Brazil
ROBTEC DO BRASIL
Phone +55 11 3318 5100
info@robtec.com

China
Pro-Technic Machinery Ltd.
Phone +852 2428 2727
atd@protechnic.com.hk

Croatia, Slovenia
Topomatika d.o.o.
Phone +385 91 5046 239
info@topomatika.hr

Czech Republic
MCAE Systems s.r.o.
Phone +420 549 128 811
mcae@mcae.cz

Denmark
Zebicon
Phone +45 7650 9152
info@zebicon.com

Finland
Cascade Computing AB
Phone +358 40 515 3341
info@cascade.fi

Greece
EXPERTCAM
Phone +30 210 2757 410
exp@cam@otenet.gr

Hungary
R-Design Studio Ltd.
Phone +36 1 365 10 89
info@r-design.hu

India
APM Technologies
Phone +91 11 4163 1416
apmtech@vsnl.net

Indonesia
PT Henindo
Phone +62 21 489 9675
henvgs@attglobal.net

Iran
Fadak Sanat Gostar (FSG)
Phone +98 21 88 730 735
info@fadaksanat.com

Italy
MICROSYSTEM SRL
Phone +39 051 4145611
info@microsystem.it

Japan
Marubeni Solutions Corp.
Phone +81 3 5778 8571
Sato-Yoshiyuki@marubeni-sys.com

Malaysia, Singapore
First High Tech Sdn Bhd
Phone +603 7665 2188
info@1st.com.my

Mexico
CIM Co.
Phone +52 55 5565 6633
info@cimco.com.mx

Pakistan
Ultimate CAD Solutions Ltd
Phone +92 51 5467572
shakir@ucs-int.com

Poland
ITA
Phone +48 61 843 6344
info@ita-polska.com.pl

Portugal
S3D
Phone +35 12 4457 3100
suporte@s3d.pt

Romania
SPECTROMAS SRL
Phone +40 21 3105190
info@spectromas.ro

South Africa
RGC Engineering Pty
Phone +27 11 531 0766
info@rgcengineering.co.za

South-Korea
OMA Co.
Phone +82 42 822 9501
support@omagom.co.kr

Spain
Metronic S.A.
Phone +34 943 121400
comercial@metronicnet.com

Sweden
Cascade Computing AB
Phone +46 31 84 0870
info@cascade.se

Taiwan
Road Ahead Technologies
Phone +886 2 2999 6788
marcel@rat.com.tw

Thailand
Mentel Co., Ltd.
Phone +662 719 6969
info@mentel.co.th

Turkey
Cadem A.S.
Phone +90 216 557 64 64
gom@cadem.com.tr

USA
Capture 3D Inc.
Phone +1 714 546 7072
jgout@capture3d.com

USA
Trillion Quality Systems LLC
Phone +1 215 710 3000
info@trillion.com

Venezuela
AT Group Software Inc
Phone +58 212 9432 446
dkinz@atgroup.com.ve

Vietnam
AIE
Phone +84 43 7345 435
aie@vnn.vn

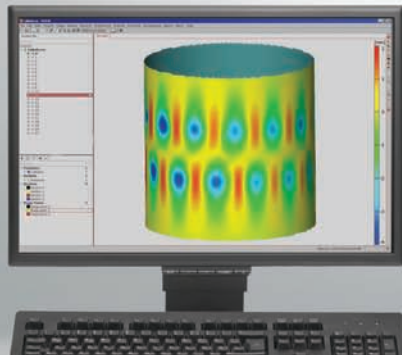

gom
Optical Measuring Techniques

GOM mbH
Mittelweg 7-8
38106 Braunschweig
Germany
Tel +49 531 390 29 0
Fax +49 531 390 29 15
info@gom.com

www.gom.com

GOM International AG
Bremgarterstrasse 89B
8967 Widen
Switzerland
Tel +41 5 66 31 04 04
Fax +41 5 66 31 04 07
international@gom.com

GOM UK Ltd
Business Innovation Centre
Coventry, CV3 2TX
United Kingdom
Tel +44 2476 430 230
Fax +44 2476 430 001
info-uk@gom.com

Trillion
Optical Test Systems

Trillion Quality Systems
500 Davis Drive, Suite 200
Plymouth Meeting, PA 19462
Tel: (215) 710-3000
info@trillion.com
www.trillion.com